

75F[®] Central Control Unit[™]

A wireless building management system providing in-depth, real-time insight and control.

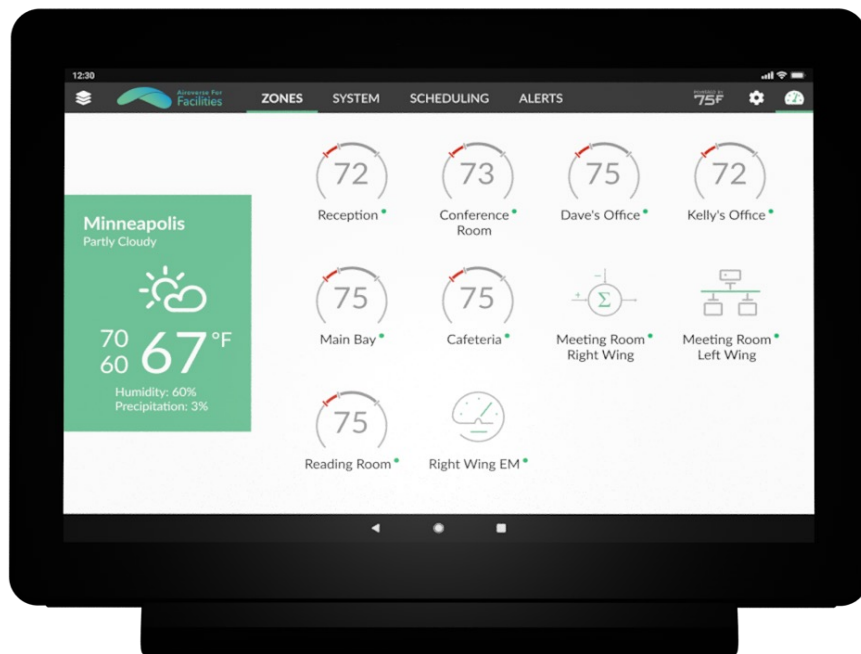

- Intuitive mobile pairing, configuration and settings setup
- View space temperatures and equipment operating conditions
- Make scheduling and setpoint adjustments
- Manage alerts with severity color coding
- Easy and secure magnetic alignment and spring-based locking slider for the removeable tablet
- Wall mounting compatible with industry standard vertically installed junction boxes

75F® Central Control Unit™

What do you get when you combine a state-of-the-art control supervisor and an applied equipment controller? Answer: the 75F Central Control Unit (CCU), a removable wall-mounted tablet, on-site user interface for building management, and gateway to the 75F cloud.

Customers appreciate real-time data visualization and graphs, zone and equipment-specific performance and status. The elegant and modern design snaps easily and securely into place with a spring-based locking slider.



OVERVIEW

The 75F Central Control Unit (CCU) is a wall-mounted communication gateway. It connects the 75F terminal devices via the local 900 MHz wireless mesh network and connects to Modbus devices via RS485. The data it collects from these devices is then sent to the 75F cloud with a Wi-Fi or LAN connection.

The CCU also acts as a zoned AHU controller or optimization extension. It aggregates all the terminal zone data to make more informed decisions about how and when to activate the system AHU.

KEY FEATURES

- Controls single and multi-stage systems, heat pump systems, fan coil units, air handlers, and more.
- Control up to 48 terminal equipment modules per Central Control Unit.
- Auto changeover.
- Proactive, predictive control in conjunction with 75F cloud servers; operates connected to the 75F cloud or standalone without an internet connection.
- Strong, permanent magnets and metal locking tabs help with feel and secure alignment.
- Intuitive Android-based user interface.

ADDITIONAL FEATURES

- Powerful MT8163, quad core processor with 2GB RAM and 32 GB Flash Memory
- Easy mobile pairing, configuration and settings setup.
- Zones status
- Schedule and setpoint adjustments
- Alerts with severity color coding

COMPATIBLE APPLICATIONS

- 75F Dynamic Airflow Balancing
- 75F Outside Air Optimization
- 75F Smart VAV with Reheat
- 75F Single Stage Equipment Controls

INCLUDED

(1) Central Control Unit

(1) Wall Sensor

Mounting Hardware



75F® Central Control Unit™

MECHANICAL

Dimensions	8.2" x 5.7" x 0.5" (208.5mm x 145mm x 11.5mm)
Mounting	(2) #8 screws over standard electrical junction box
Screen	8" display, 1200 x 800
Operating Temp	32°F to 122°F (0°C to 50°C)
Termination	Common Pogo Pin termination for USB port and +5V DC power
Microprocessor	Processor MT8163, quad core, 64-bit, Cortex – A53, 1.3GHz
HVAC Control	Up to 5 stages of heating/cooling, up to 5 fan stages, 0-10V modulating output for heating/cooling valves (no VFD), and a dehumidifier or humidifier

WALL PLATE

Dimensions	7.96" x 5.1" x 1.02" (202.16mm x 129.29 mm x 25.87mm)
-------------------	---

I/O

Inputs	A. (2) 0-10V analog inputs B. (2) 10k thermistor inputs
Outputs	C. (4) 0-10V or 4-20V mA analog outputs D. (7) 24V DC/1A relays

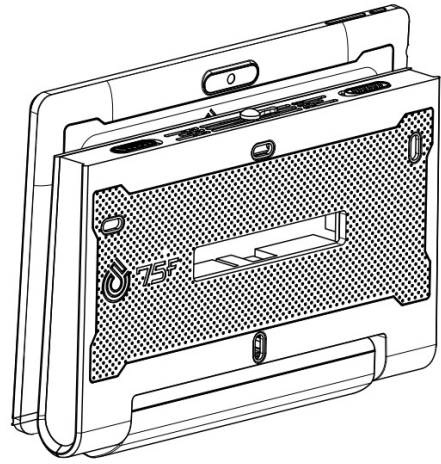

ELECTRICAL

Supply	24V AC/DC
Consumption	5 VA (typical), 10 VA (max)
Battery	3.7V, 2500mAH, Lithium Polymer

COMMUNICATIONS

Bluetooth	BLE 4.1 used for pairing devices (e.g. 75F Smart Node equipment control)
Mesh	900 MHz IEEE 802.15.4-compliant; used for device communication on mesh network
Wired	Sensor Bus to Wall Sensor
Wi-Fi	Wi-Fi to connect to internet

